



HP Indigo W7200 Digital Press

Application-focused, offset quality with high-volume digital productivity



Progressive Profitable Printing

- 1 Attention lights:
Allow operator to monitor multiple presses without remaining in immediate vicinity.
- 2 External blanket heating:
Accurate local temperature control optimizing print process per substrate type.
- 3 Charge roller.
- 4 Binary Inking Developers (BID's).
- 5 Rewinder.
- 6 Inline densitometer (ILD):
Dual engine synchronized system assures color consistency, fidelity, dot gain compensation and accurate repeatability across jobs, and between engines. Motorized ILD enables self-calibration and optimized color calibration.
- 7 Internal buffering system.

- 8 Buffering Control Unit (BCU):
Enables printing different number of separations on each print engine in the highest productivity. The unit includes inspection table, buffering, turn bar & web guide.
- 9 Touch screen user interface:
Intuitive and easy-to-use remote assistance diagnostic & resolution tools. Entire press can be operated from user panel on either engine.
- 10 One-shot process:
Assures perfect color registration by accumulating all image separations on the blanket and transferring them to the substrate simultaneously in one shot.

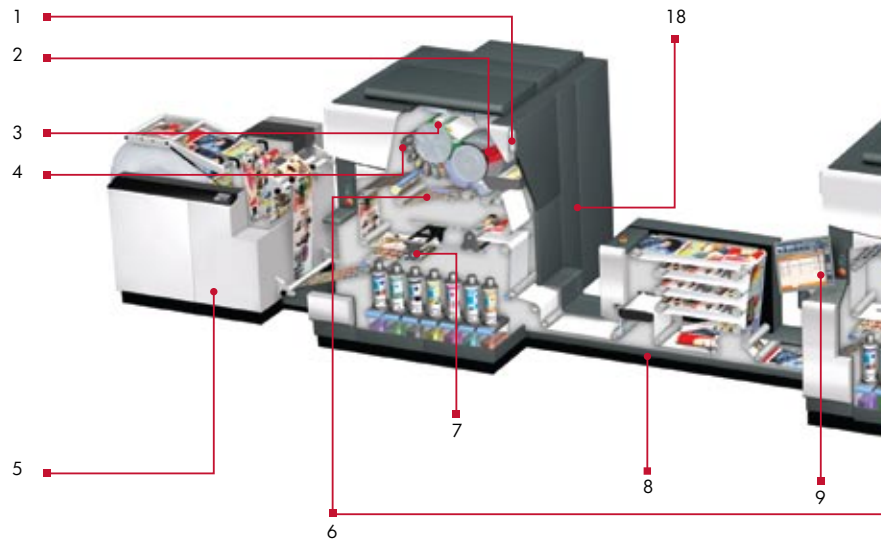

Accelerate your business with new application opportunities

- Deliver on-demand, short-run books, journals, manuals, yearbooks, and magazines with unmatched print quality.
- Print high-impact, high-volume personalized, direct marketing campaigns in full color.
- Produce revenue-building, attention-grabbing TransPromo statements.
- Print high-value, high-volume photo specialty products with unmatched production automation and efficiency production.*

The new dual-engine, continuous-feed HP Indigo W7200 Digital Press clearly raises the bar for digital productivity, while setting you apart competitively with outstanding offset quality. Building on the success of the HP Indigo press w3250, the new HP Indigo W7200 Digital Press includes features requested by existing commercial web customers.

A powerful combination: fast, offset quality for high-volume runs

The HP Indigo W7200 Digital Press is the premier digital solution for adding high productivity and true offset quality for large-volume, highly variable “every page is different” production runs. It’s a powerful combination available only from HP Indigo.

Operating at throughput speeds of 240 full-color images or 960 one-color images per minute, the HP Indigo W7200 Digital Press produces more than 7.5 million color images per month. With an architecture and toolset built for high productivity and reliability, you can meet the tightest deadlines and the toughest mission-critical requirements.

As in all HP Indigo digital presses, HP ElectroInk liquid ink is the proprietary underlying technology delivering proven offset and photo quality from the HP Indigo W7200 Digital Press—and your distinct quality advantage compared to other digital presses. You can produce CMYK process color jobs with an extensive color gamut, and achieve PANTONE® emulation with 4, 6, and 7 colors mixed

on-press. You can also create special spot colors off-press—using the exclusive HP Indigo Ink Mixing System—to accurately match your clients’ corporate branding and custom color requirements. On-press Fast Ink Replacement technology enhances productivity by letting the operator switch spot color inks while the press is running. The press supports jobs with high ink coverage—regardless of color—with finely detailed, highly accurate quality.

Deliver a broad range of jobs for a dynamic marketplace

With its robust productivity, the HP Indigo W7200 Digital Press gives you the ability to address a wider range of long-run jobs. You can offer your customers a variety of value-added services and applications, such as print-on-demand services for books, journals, and manuals, as well as VDP capabilities for personalized direct marketing, self mailers, inserts, postcards, and TransPromo statements.

Without any compromise in productivity, the HP Indigo W7200 Digital Press supports substrates with thicknesses from 27 lb text—to satisfy requests for the lightest papers—up to 130 lb cover, including coated, uncoated, and recycled stock. By supporting an image format of 12.5 x 38.6 inches, the press increases your ability to run more jobs and new applications not previously possible, with cost-effective, highly efficient page imposition, and media use.

The HP SmartStream Production Pro is a robust off-press Digital Front End (DFE) that manages and drives jobs to the HP Indigo W7200 Digital Press—which runs at full speed. Controlled from a centralized pre-press or IT location, it uses lights out automation and scalability to balance print loads among multiple presses. With expandable computing power and storage space, it gives you ample capacity for driving the press 24/7 while pre-press operators are not in the shop. This DFE also supports the most common industry standard file formats, including PDF, PPML, and AFP.

Anchored by the HP Indigo W7200 Digital Press, your customized, end-to-end solution includes optimized third-party hardware and software offerings. When producing brochures and postcards, you can apply inline UV coating,

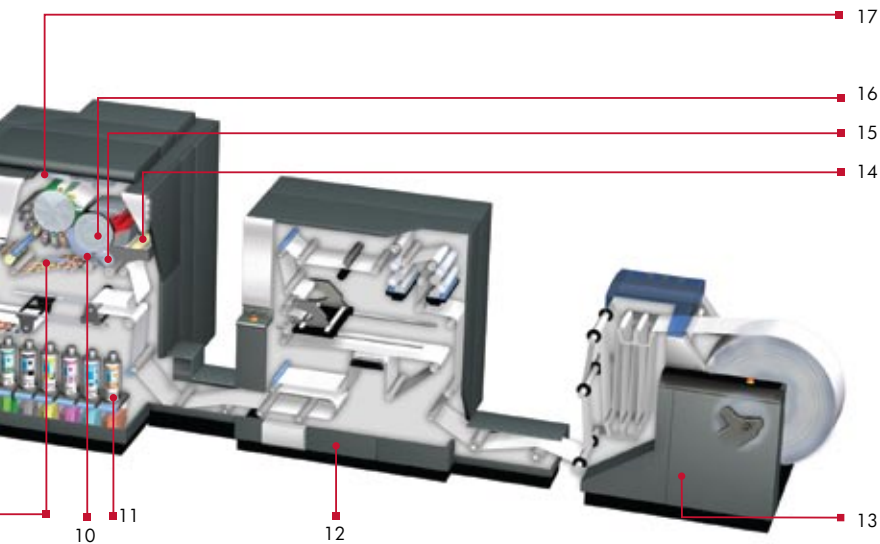

- 11 Ink cabinet:
 - Liquid ElectroInk achieves best-in-class print quality.
 - 7color stations allow Pantone emulation of 4, 6, 7 process colors and spot colors.
 - On-the-fly On-press Fast Ink Replacement (OFIR) system.
 - Enlarged ink cans.
- 12 In-Line Priming Unit (ILP): Enables the use of a wide substrate range including: commodity coated, uncoated and recycled papers.
- 13 Unwinder.
- 14 Blanket Cleaning Station (BCS).
- 15 Impression cylinder.
- 16 Blanket cylinder: Supports high print speed, wide substrate gamut and 38.6 inches long format.
- 17 High speed writing head: 812dpi (8 Bit/pixel) at 775 Mpix/sec using a 22 beam laser.
- 18 Imaging oil recycling system: Limits environmental footprint by reducing oil consumption as well as waste.

punching, and corner rounding. For books and manuals, the press quickly delivers stacked, bind-ready book blocks without operator intervention.

Low total cost of ownership = increased profits

HP Indigo offers extremely attractive programs that lower variable charges as your volumes increase—and special pricing for low coverage applications. Pricing for monochrome printing is highly competitive as well, increasing your business profitability.

Your media costs remain low with an inline priming system (ILP) on the HP Indigo W7200 Digital Press that allows you to order a broad range of standard, off-the-shelf, affordable substrates.

And of course, HP offers attractive financing options and flexible terms that facilitate the acquisition of your press.

Print-on-demand books reduce cost and waste

The HP Indigo W7200 Digital Press lets you take advantage of the expanding market for short-run, print-on-demand books, journals, and magazines. The end-to-end solution combines high productivity and offset quality with broad substrate support, inline finishing that delivers stacked, bind-ready book blocks and optimized partner solutions that enable fully automated matching and binding. You'll also benefit from cost-efficient monochrome book and journal block production.

Print personalized, direct marketing campaigns in full color

The HP Indigo W7200 Digital press provides the most efficient, cost-effective solution for producing high-impact, high-volume, personalized direct mail pieces that people really notice. Printed in full-color, offset quality, personalized images, and text, add powerful impact to letter packages, self-mailers, postcards, reply cards, folders, and brochures.

The press can print up to seven colors at high coverage on any type of substrate, creating high-quality, direct mail applications that drive higher response levels. The HP Indigo team, through its Strategic Account Program, assists its customers in defining and installing end-to-end solutions. These solutions enable a variety of possibilities, for example, connecting an inline finishing solution that delivers UV coated, cut to size postcards that are ready to be sent to the mail stream.

TransPromo marketing makes a big statement

The HP Indigo W7200 Digital Press is tailor-made to take advantage of profitable growth opportunities, such as TransPromo statements. It offers the added value of exceptional offset quality at high speeds, while enabling personalized, one-to-one marketing to individual recipients.

The press can print monochrome statements at 960 ppm, full-color statements with eye-grabbing ads at 240 ppm, and two-color statements, using specific end customers' brand colors at 480 ppm.

Print photo specialty with production efficiency*

Providing higher productivity with its efficient inline finishing, the HP Indigo W7200 Digital Press delivers HP Indigo's award-winning print quality.

The HP Indigo W7200 Digital Press, when using its optional automated inline finishing solutions, delivers products such as bind-ready photo book blocks, cut and stacked cards, as well as punch-ready calendars, reducing excess labor costs and increasing efficiency.

To ensure consistent color between the dual print engines from job to job and run to run, the HP Indigo W7200 Digital Press employs a new automated color calibration system.

* Support for photo applications planned for 2010

Technical specifications

Printing speed	14,400 4-color pages per hour 28,800 2-color pages per hour 57,600 1-color pages per hour
Image quality	812 and 1219 dpi at 8 bit 2,438 x 2,438 dpi addressability HDI (High Definition Imaging) Line screen: 144, 175, 180
Image size	12.48 x 38.58 in max.
Paper format	Max. web width: 13.4 in Min. repeat length: 18.9 in (in 4-color print mode) Max. repeat length: 38.6 in
Paper weight	Roll-to-roll: 27 lb text–130 lb cover (subject to paper stiffness) Roll-to-sheet: 27 lb text–110 lb cover (subject to paper stiffness)
Paper input system	Input roll max. diameter: 51.2 in Input roll inner core diameter: <ul style="list-style-type: none">• Standard: 3 in• Optional: 6 in
Press dimensions (including in-line priming and unwinder)	Length: 38 ft 8 in Width: 7 ft 6 in Height: 6 ft 10 in
Press weight (including in-line priming and unwinder)	15,653 lb

Optional equipment/configuration:

Expanded color capabilities	5-, 6-, and 7-color printing HP IndiChrome Ink Mixing System
Paper output system	Rewinder: Hunkeler Rewind RW6 Cutting and offset stacking: Hunkeler POPP6 Combination line available Or other customized solutions according to the customer's need

North America

Hewlett-Packard Company
Summit Boulevard 1001
Mailstop 401
Atlanta, GA 30319
USA
Tel: +1 800 289 5986
Fax: +1 404 648 2054

Europe, Middle East and Africa

Hewlett-Packard Company
Avenue Céramique 241
6221 KX Maastricht
The Netherlands
Tel: +31 88 750 1723
Fax: +31 88 750 1715

Asia Pacific

Hewlett-Packard Company
Depot Road 138
Singapore 109683
Tel: +65 6727 0777
Fax: +65 6276 3160

Latin America

Hewlett-Packard Company
Blue Lagoon Drive 5200
Suite 950
Miami, FL 33126
USA
Tel: +305 267 4220
Fax: +305 265 5550
informahpindigo@hp.com

Israel

Hewlett-Packard Company
Kiryat Weizmann
P.O. Box 150
Rehovot 76101
Israel
Tel: +972 8 938 1818
Fax: +972 8 938 1338



To learn more, visit www.hp.com/go/graphic-arts or
www.hp.com/go/myhpindigoweb

© 2009 Hewlett-Packard Development Company, L.P. The information contained herein is subject to change without notice. The only warranties for HP products and services are set forth in the express warranty statements accompanying such products and services. Nothing herein should be construed as constituting an additional warranty. HP shall not be liable for technical or editorial errors or omissions contained herein.

PANTONE® and other PANTONE, Inc. trademarks are the property of PANTONE, Inc.
4AA1-7735ENUS, August 2009. This is an HP Indigo digital print.

